

Hippo[©]

The 1st Heavy Duty
Hydro X Nozzle
...that Loves Mud...



 **DIRECT HIT[®]**

2019

Actual Size of a Hippo® HD Hydro X Nozzle Assembly.

The HE38HD is the 1st Heavy Duty reverse turbo nozzle specifically designed for the hydro excavation industry. The seat is locked in position and can not move in-wards towards the rotor and damage it. The rotor can be dismantled on site to be cleaned from any debris. The outside black protection cover can be replaced by unscrewing it and putting a new one back on.

Spare parts can be purchased individually to make new size nozzles and repair kits.

Hippo®

The NEW way to hydro excavate!

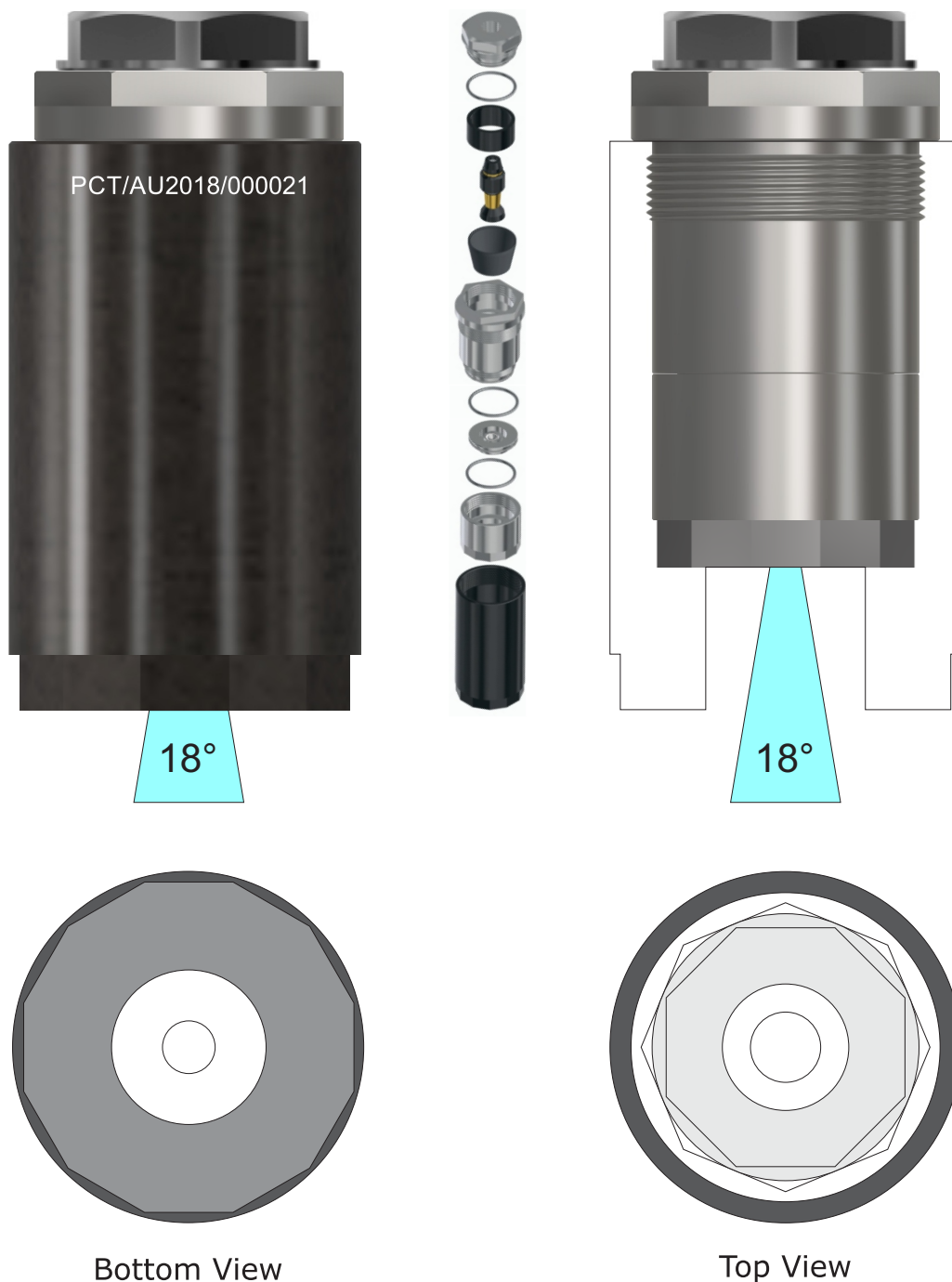

Gun and Lance Kit Accessories

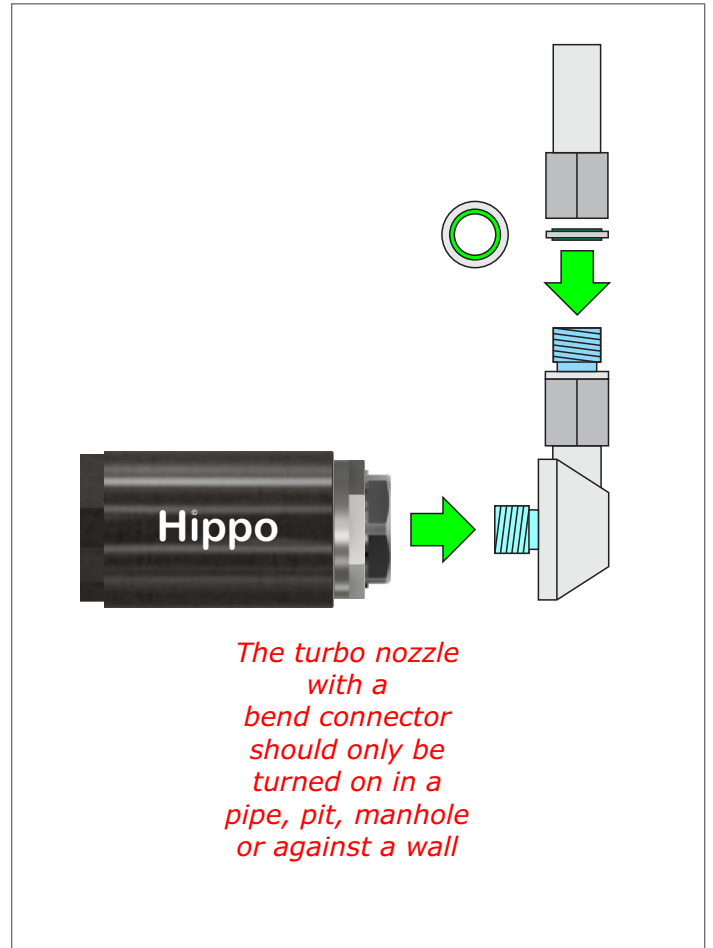
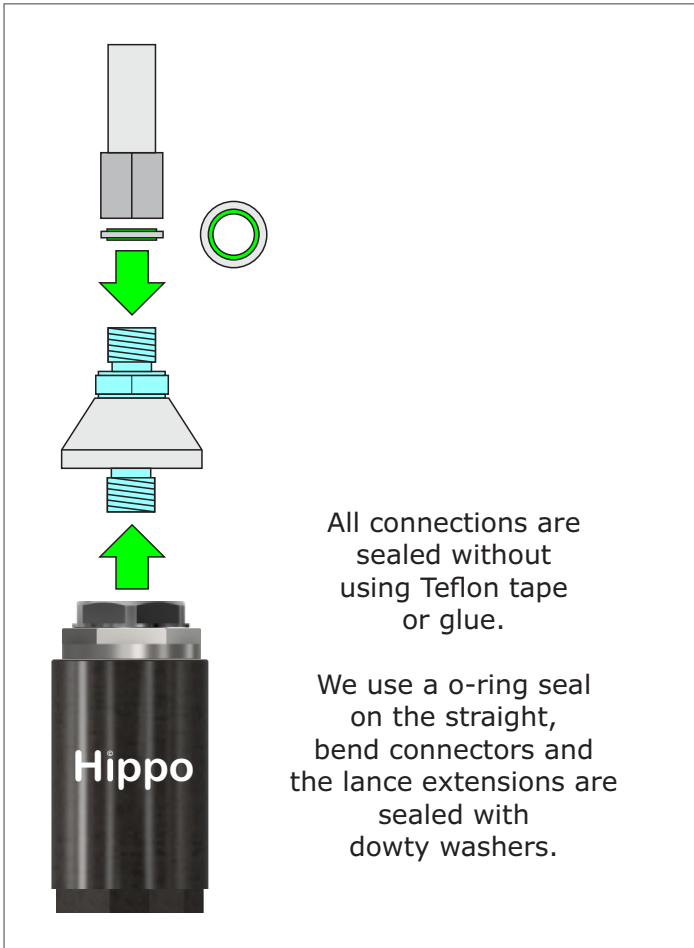
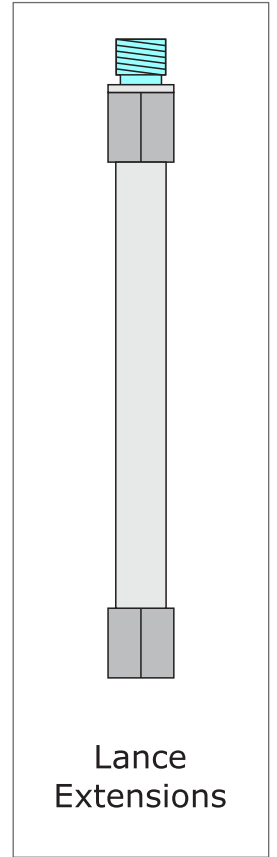
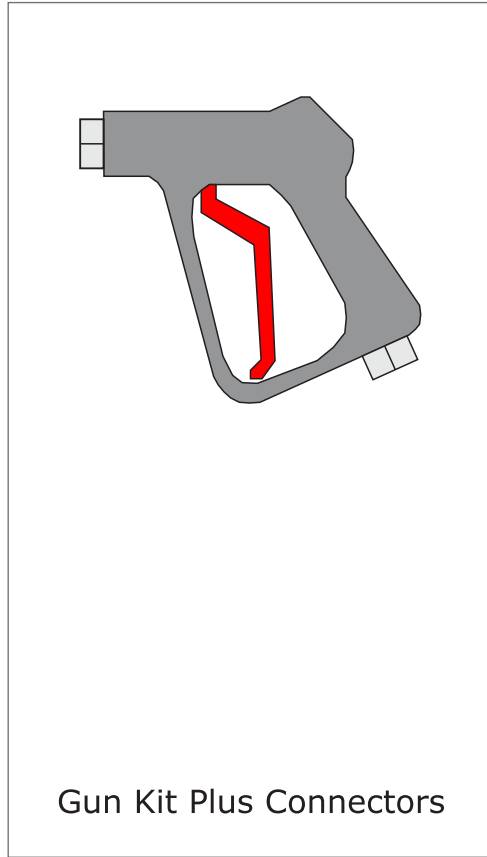
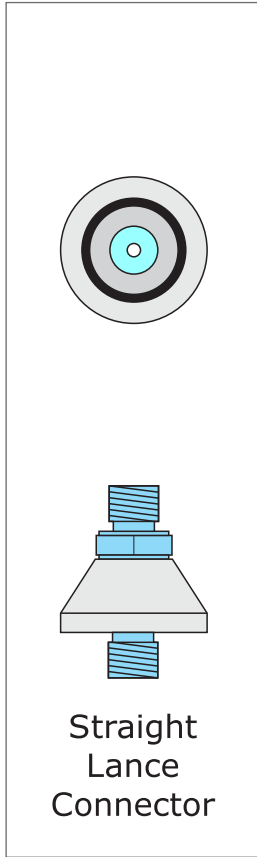
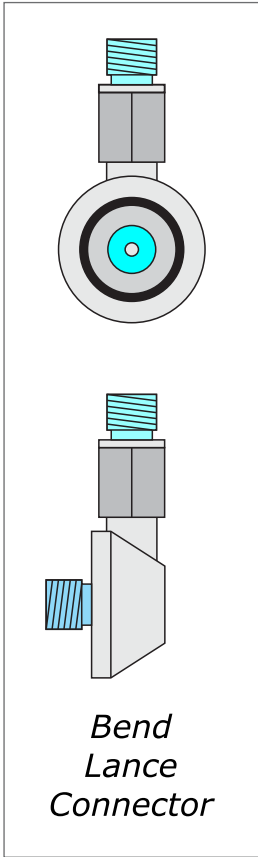

Hydro excavate to locate and clean around the pipe.

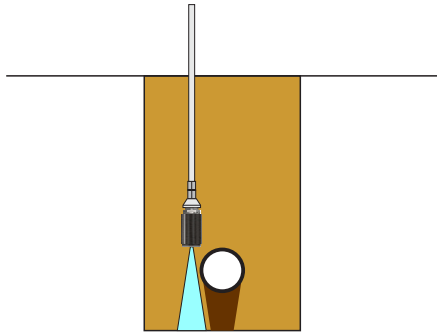

Hydro excavate the trench

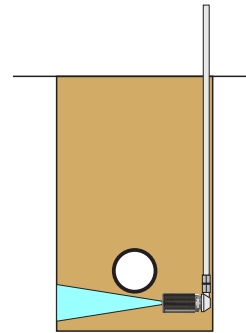

The turbo nozzle with a bend connector should only be turned on in a pipe, pit, manhole or against a wall

Hydro excavate under the pipe

18°, 24° and 30° SS Turbo Nozzles

18 degree turbo nozzle
at 100 mm of the surface
32 mm water cone

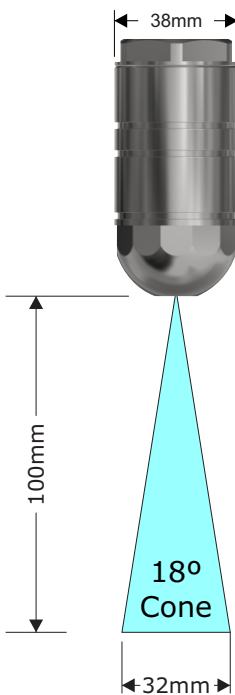

24 degree turbo nozzle
at 100 mm of the surface
42 mm water cone

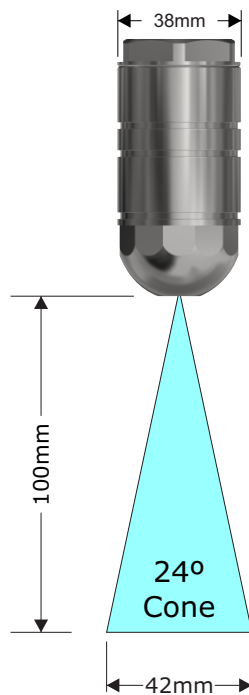

30 degree turbo nozzle
at 100 mm of the surface
55 mm water cone

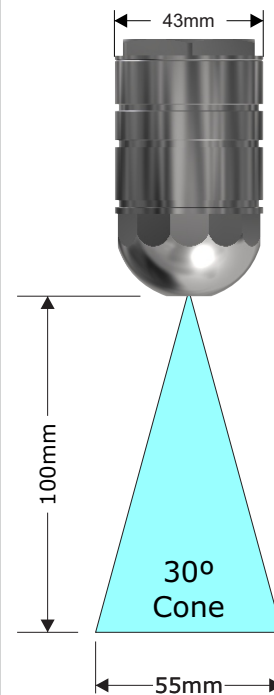

Hippo HD Hydro X Nozzle assembly part list.



1.Hydro X Nozzle 2.Protective cover 3.Hydro X Nozzle without cover 4.Unscrewed front seat nut
5.Dismantled Hydro X Nozzle 6.Rotor 7.Rubber cone 8.Top insert

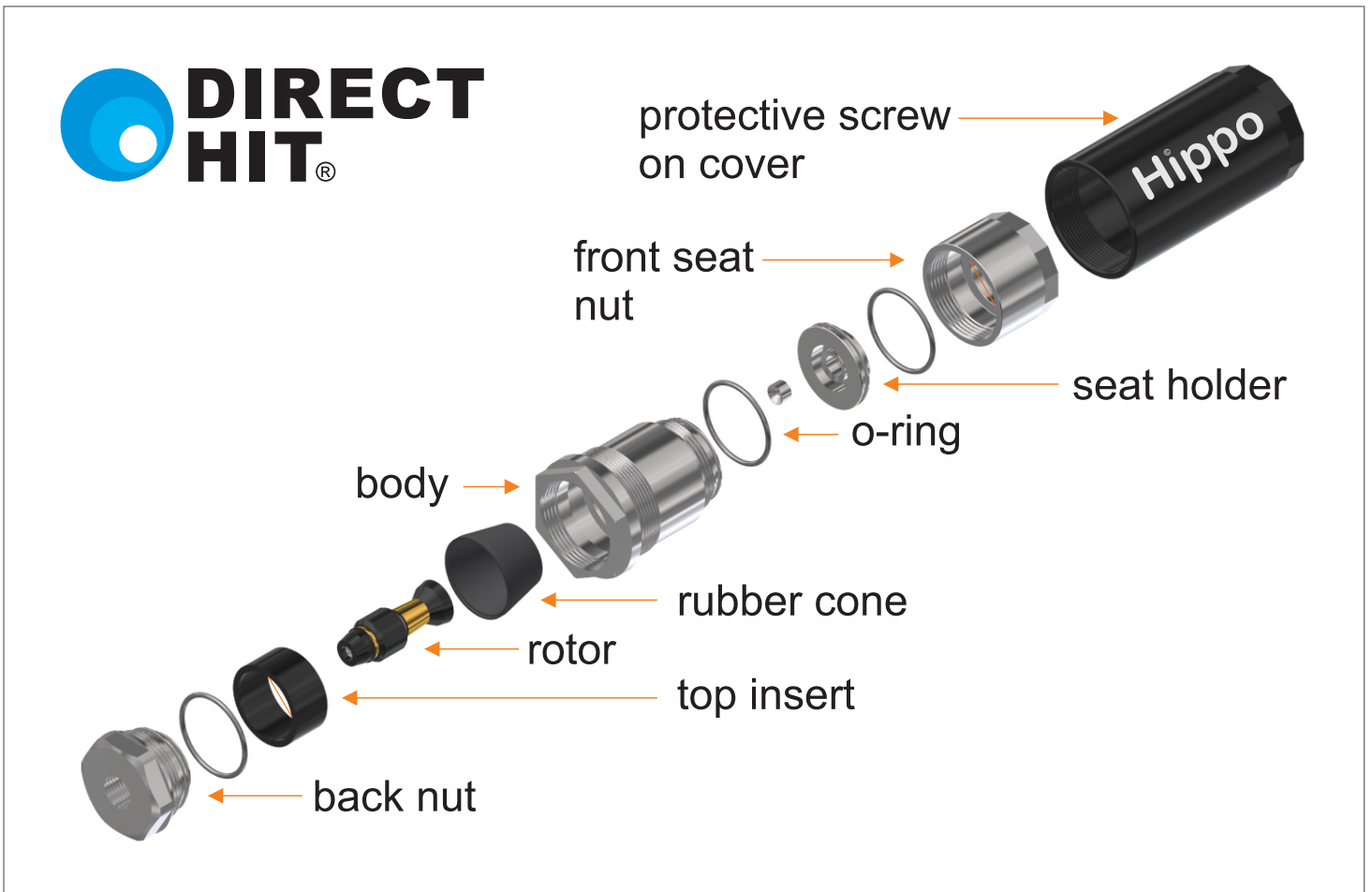

How to clean out/unblock the rotor.

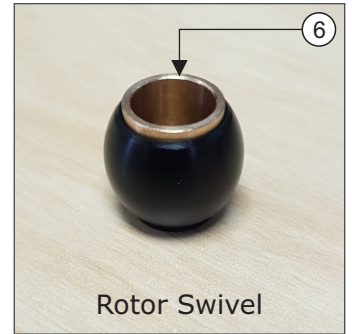
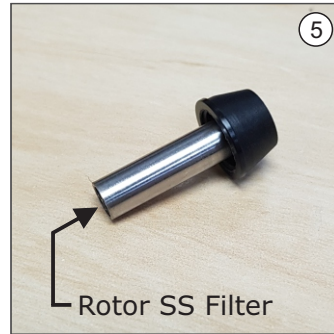
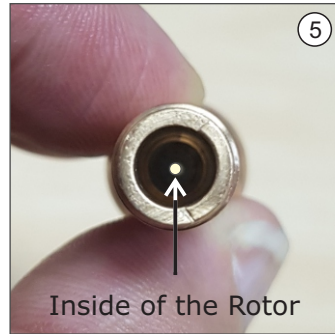
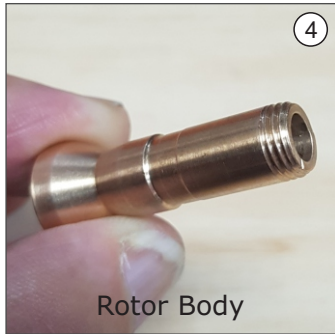
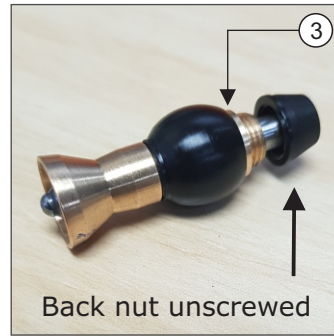
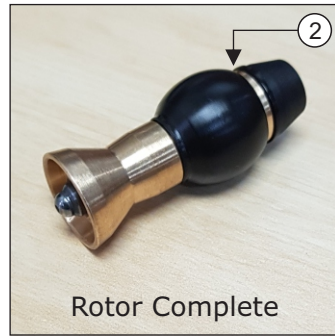

Instructions:

1. Unscrew the back nut with the DH custom spanners.
2. Remove the rotor from the nozzle assembly.
3. Un screw the back plastic cap anti-clockwise by hand (no tools).
4. Pull out the SS filter assembly.
Remove the swivel.
5. Check inside of the rotor body and SS filter for debris.
If blocked clean out debris.

If clean install the swivel back on to the rotor body.

Note: The brass ring of the swivel to face the black plastic SS filter end (**Figure 2-3-6**).

Screw on the SS filter with the black plastic cap hand tight (no tools).

Place rotor jet onto the seat in the nozzle assembly.

Screw on the back nut with the DH custom spanners.

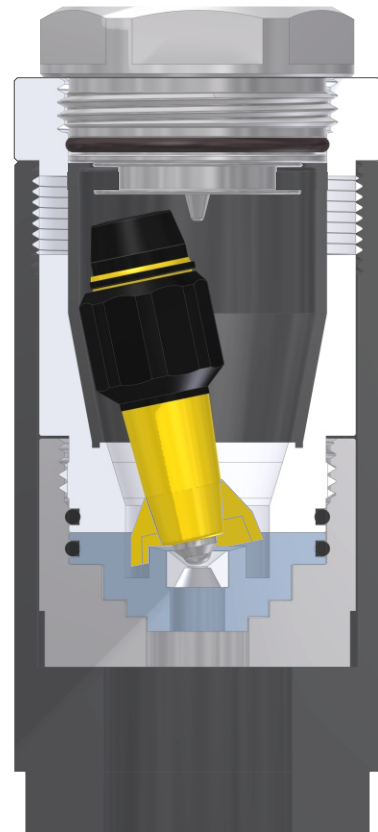

Hippo HD Hydro X Nozzle (Size 2.0 to 12.0).

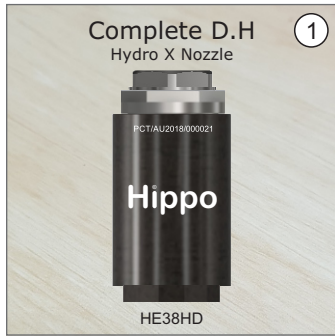

Direct Hit®
 Designs/manufactures
 in AU, retrofit kits &
 repair kits
 to suit:
 -HXXpose
 -Prospector
 -Ripsaw
 -Ripsaw HD
 (Hydro Excavation Nozzles)

HE38HD Hydro X Nozzle, Retrofit and Repair Kit:

1. **300-100-045**.....(HE38HD 4.5 Hydro X Nozzle DS*)
2. **300-150-045**.....(HE38HD 4.5 Retrofit Kit DS*)
3. **300-200-045**.....(HE38HD 4.5 Repair Kit DS*)
4. **300-250-045**.....(HE38HD 4.5 Short Rotor Kit DS*)

DS*: Rotor can be dismantled for easy clean (Page 7).

045: Nozzle size

Change your nozzle size bellow to work with lower pressure or lower liters*.

Nozzle Selection Chart (Pressure is Bar or PSI and Flow is liters per minute)																						
Psi	870	1160	1450	1740	2030	2175	2320	2610	2900	3190	3480	3625	4060	4350	4640	5075	5510	5800	6090	6525	6960	7250
Bar	60	80	100	120	140	150	160	180	200	220	240	250	280	300	320	350	380	4000	420	450	480	500
Size	litres/min																					
2.0	3.6	4.1	4.6	5.0	5.4	5.6	5.8	6.0	6.5	6.8	7.1	7.3	7.7	8.0	8.2	8.6	9.0	9.2	9.4	9.8	10.1	10.3
3.0	5.2	6.0	6.7	7.3	7.9	8.2	8.5	9.0	9.5	9.9	10.4	10.6	11.2	11.6	12.0	12.5	13.1	13.4	13.7	14.2	14.7	15.0
4.0	7.0	8.1	9.1	10.0	10.8	11.1	11.5	12.2	12.9	13.5	14.1	14.4	15.2	15.8	16.3	17.0	17.7	18.2	18.6	19.3	19.9	20.3
4.5	8.0	9.2	10.3	11.3	12.2	12.6	13.0	13.8	14.6	15.3	16.0	16.3	17.2	17.8	18.4	19.3	20.1	20.6	21.1	21.8	22.6	23.0
5.0	8.7	10.0	11.2	12.3	13.3	14.2	15.0	15.8	16.6	17.4	17.7	18.7	19.4	17.8	22.0	21.0	21.8	22.4	23.0	23.8	24.8	25.0
5.5	9.8	11.3	12.6	13.8	14.9	15.4	15.9	16.9	17.8	18.7	19.5	19.9	21.1	21.8	22.5	23.6	24.6	25.2	25.8	26.7	27.6	28.0
6.0	10.6	12.3	13.7	15.0	16.1	16.8	17.3	18.4	19.4	20.3	21.2	21.7	22.9	23.7	24.5	25.6	26.7	27.2	28.1	29.1	30.0	30.6
8.0	14.1	16.3	18.2	19.9	21.5	22.3	23.0	24.4	25.7	27.0	28.2	28.8	30.5	31.5	32.6	34.0	35.5	36.4	37.3	38.6	39.9	40.7
10.0	17.8	20.6	23.0	25.2	27.2	28.2	29.1	30.9	32.5	34.1	35.6	36.4	35.5	39.8	41.4	43.0	44.8	46.0	47.1	48.4	50.4	51.4
12.0	20.9	24.1	27.0	29.6	31.9	33.1	34.21	36.2	38.2	40.0	41.8	42.7	45.2	46.8	48.3	50.5	52.6	54.0	55.3	57.3	59.2	60.4

* For example, you are using a 4000Psi (280Bar) pump at 21l/min. Barliters= Bar pressure from your pump x the l/min it produces. Class A states the jetter operates between 800 to 5600 Barlitres per minute. 5600 Barliters ÷ by your pressure 280 Bar= 20 liters maximum you can use. You will use a 5.0 Nozzle and adjust your unloader valve to 4000Psi. Now if you are using 3/8 x 30m hose, you will loose 90Psi pressure at the lance-gun. If you are using 1/4 x 30m hose you will have at the end 3347 Psi losing 653Psi. When you want to drop to 2000 psi insted of dropping the revs on your motor, in the above chart go across to 2030 psi, down to 21.5 liters and you will use a 8.0 nozzle. If you want to use less water at the same pressure go to a smaller size nozzle.

Because we are continuously improving our products and services, Direct Hit reserves the right to change the specifications and prices without prior notice.

18°, 24° or 30° SS Turbo Nozzles (Size 2.0 to 12.0).



1. The 38mm SS Turbo Nozzle has a 18 degree cone of coverage is used for:

- a. Light duty hydro excavation
- b. Roof tile cleaning

1. The 38mm SS Turbo Nozzle has a 24 degree cone of coverage is used for:

- a. Surface cleaning
- b. CCTV robotic high pressure drain root cutting

Note: Change the rotor swivel ball and have a 18 degree or 24 degree nozzle. Go to page 11 numbers 7 and 8 photos.



2. The 43mm SS Turbo Nozzle has a 30 degree cone of coverage is used by:

- a. Fixed position on conveyor belt for oyster cleaning
- b. Fixed position on conveyor belt for food cleaning
- c. Fish net cleaning
- d. Fixed position short distance wide angle surface and product cleaning

Nozzle ① and ② used in automatic drive through car wash

38mm outside diameter Stainless Steel turbo nozzles come with a 18° or 24° degree cone of coverage:

1. **300-318-045**.....(38 DH-18° Nozzle 4.5 SS DS)

1. **300-324-045**.....(38 DH-24° Nozzle 4.5 SS DS)

43mm outside diameter Stainless Steel turbo nozzles come with only a 30° degree cone of coverage:

2. **300-530-045**.....(43 DH-30° Nozzle 4.5 SS DS)

DS*: Rotor can be dismantled (Page 7).

045 : Nozzle size

Direct Hit®
Designs/manufactures
in AU, **retrofit kits &
repair kits**
to suit:
-HXXpose
-Prospector
-Ripsaw
-Ripsaw HD
(Hydro Excavation Nozzles)

18°, 24° and 30° Repair Kits (Size: 2.0 to 12.0).



Direct Hit®
Designs/manufactures
in AU, **retrofit kits &
repair kits**
to suit:
-HXXpose
-Prospector
-Ripsaw
-Ripsaw HD
(Hydro Excavation Nozzles)

Repair Kits (DS*):

1. **300-418-045**.....(Complete DS 18° Repair Kit with Brass Seat Kit)
1. **300-424-045**.....(Complete DS 24° Repair Kit with Brass Seat Kit)
1. **300-630-045**.....(Complete DS 30° Repair Kit with Brass Seat Kit)

Rotor Kits (DS*):

2. **300-518-045**.....(18° Complete DS Rotor with Brass Seat Kit)
2. **300-524-045**.....(24° Complete DS Rotor with Brass Seat Kit)
2. **300-530-045**.....(30° Complete DS Rotor with Brass Seat Kit)

Short Rotor Kit (DS*):

3. **300-450-045**.....(Short DS Rotor Body and Brass Seat Kit)

DS*: Rotor can be dismantled for easy clean.

4.5 : Nozzle and Rotor size

Change your nozzle size on the Standard Nozzle

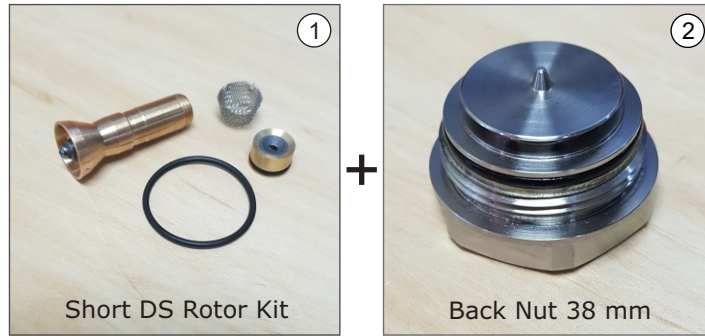

Change your nozzle size on the Heavy Duty Nozzle

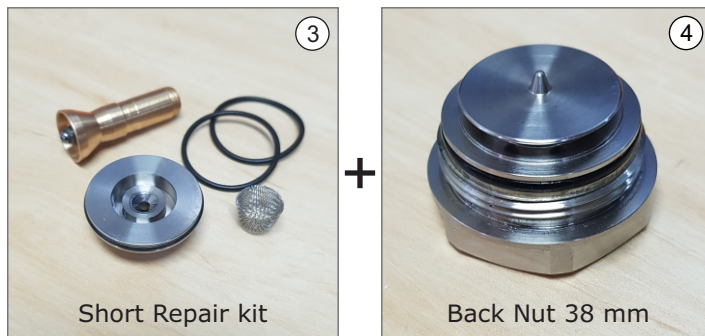

Nozzle Kit List:

1. **300-250-045**.....(Short DS Rotor Body and Brass Seat Kit)
2. **300-525-045**.....(38 mm 4.5 Back Nut Only DH)
3. **300-250-450**.....(HE38HD 4.5 Short Rotor Kit DS*)
4. **300-525-045**.....(38 mm 4.5 Back Nut Only DH)

045 : Nozzle, Rotor Jet or Back Nut size

All Nozzles Standard or Heavy duty come with sizes: 2.0 - 12.0 as shown bellow.

Nozzle set up chart:

Nozzle Size	= (1.Rotor Jet Size)	+ (2.Back Nut Size)	+ (3.Seat Range) ↔ (Seat I.D Size)
2.0	2.0	2.0	Range One ↔ I.D Size 2.4mm
3.0	3.0	3.0	Range Two ↔ I.D Size 2.9mm
3.5	3.5	3.5	Range Two ↔ I.D Size 2.9mm
4.0	4.0	4.0	Range Two ↔ I.D Size 2.9mm
4.5	4.5	4.5	Range Two ↔ I.D Size 2.9mm
5.0	5.0	5.0	Range Two ↔ I.D Size 2.9mm
5.5	5.5	5.5	Range Two ↔ I.D Size 2.9mm
6.0	6.0	6.0	Range Two ↔ I.D Size 2.9mm
8.0	8.0	8.0	Range Three ↔ I.D Size 3.3mm
10.0	10.0	10.0	Range Three ↔ I.D Size 3.3mm
12.0	12.0	12.0	Range Three ↔ I.D Size 3.3mm

Because we are continuously improving our products and services, Direct Hit reserves the right to change the specifications and prices without prior notice.

Spare Parts List.

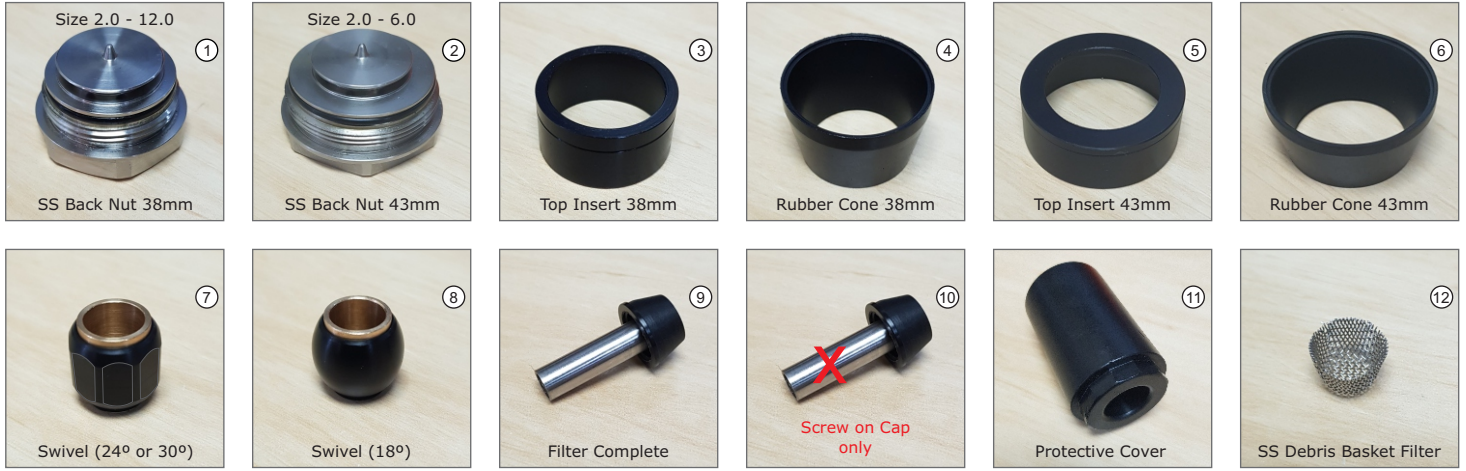

Spare Parts List:

1. **300-525-045**.....(38 mm 4.5 Back Nut)
2. **300-740-045**.....(43 mm 4.5 Back Nut)
3. **300-750-003**.....(38 mm Top Insert)
4. **300-750-004**.....(38 mm Rubber Cone)
5. **300-750-005**.....(43 mm Top Insert)
6. **300-750-006**.....(43 mm Rubber Cone)
7. **300-750-007**.....(Octagon Ball Rotor Swivel)
8. **300-750-008**.....(Ball Rotor Swivel)
9. **300-750-009**.....(Laminar Tube Assembly)
10. **300-750-010**.....(Rotor Body Screw on Cap)
11. **300-750-011**.....(HE38HD Acetal Black cover)
12. **300-750-012**.....(10 x SS Debris Filters)
13. **300-750-013**.....(HE38HD Body)
14. **300-750-014**.....(HE38HD Seat Holder Cap)
15. **300-750-015**.....(38 mm SS DH Body)
16. **300-750-016**.....(43 mm SS DH Body)
17. **300-750-017**.....(DH SS Open End Spanner)
18. **300-750-018**.....(DH SS Ring Spanner)
19. **300-750-019**.....(5 x O-Ring BS023 N70)
20. **300-750-020**.....(5 x O-Ring BS027 N70)

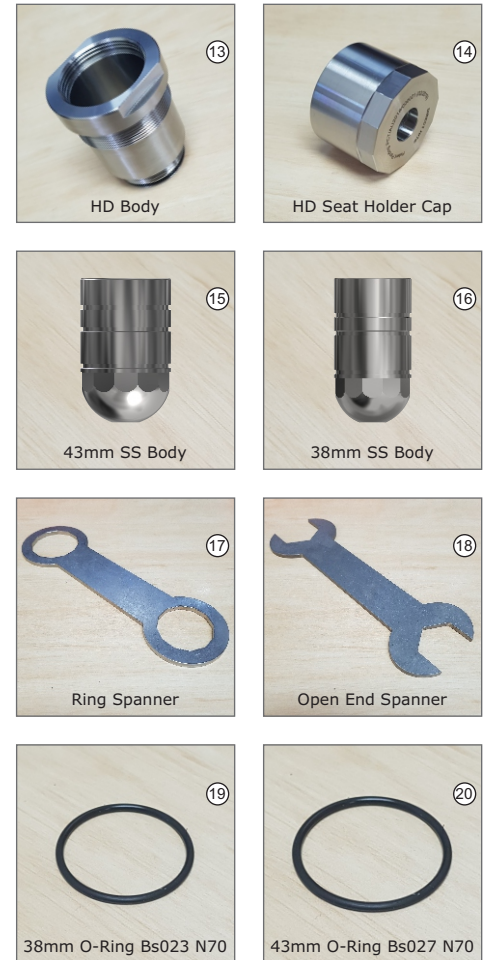

Because we are continuously improving our products and services, Direct Hit reserves the right to change the specifications and prices without prior notice.

How to assemble the Hydro X Nozzle

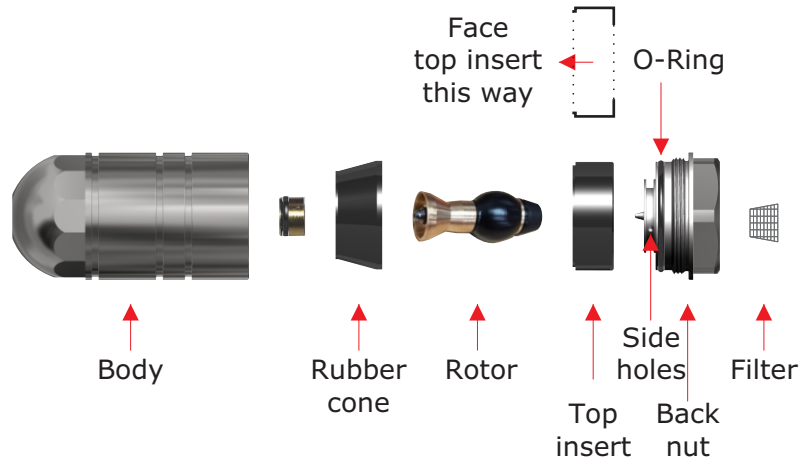

www.DirectHitSewerNozzles.com

How to assemble the Heavy Duty Hydro X Nozzle

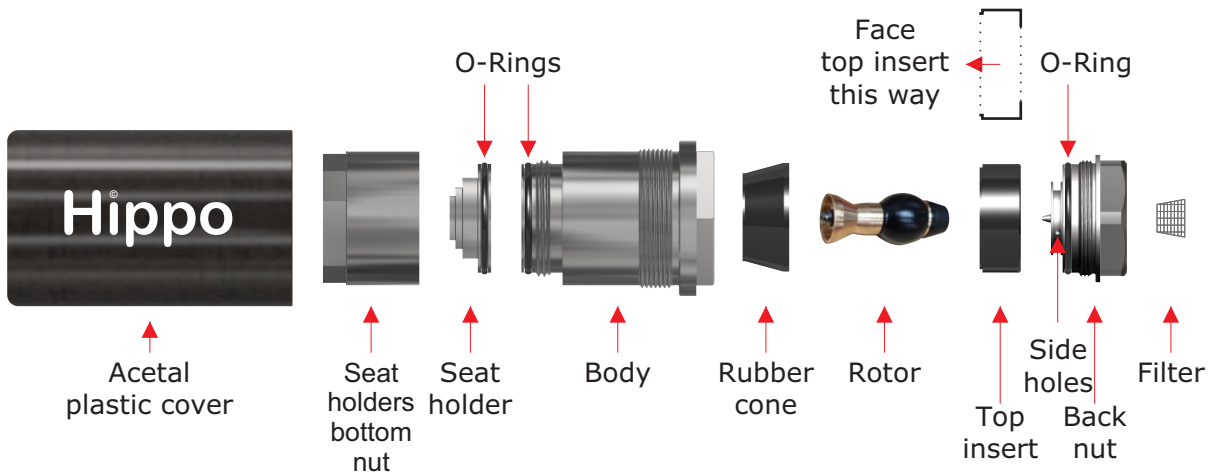

www.DirectHitSewerNozzles.com